

1 2 3 4 5 6 7 8

H
G
F
E
D
C
B
A

H
G
F
E
D
C
B
A

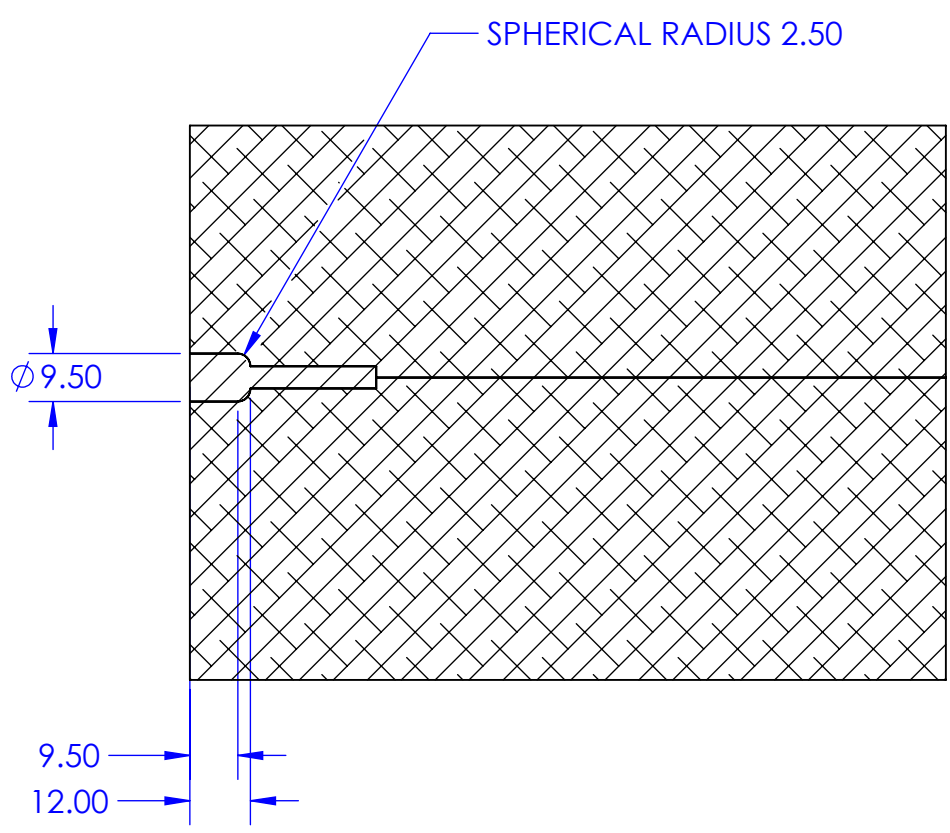

SECTION A-A
SCALE 2 : 3

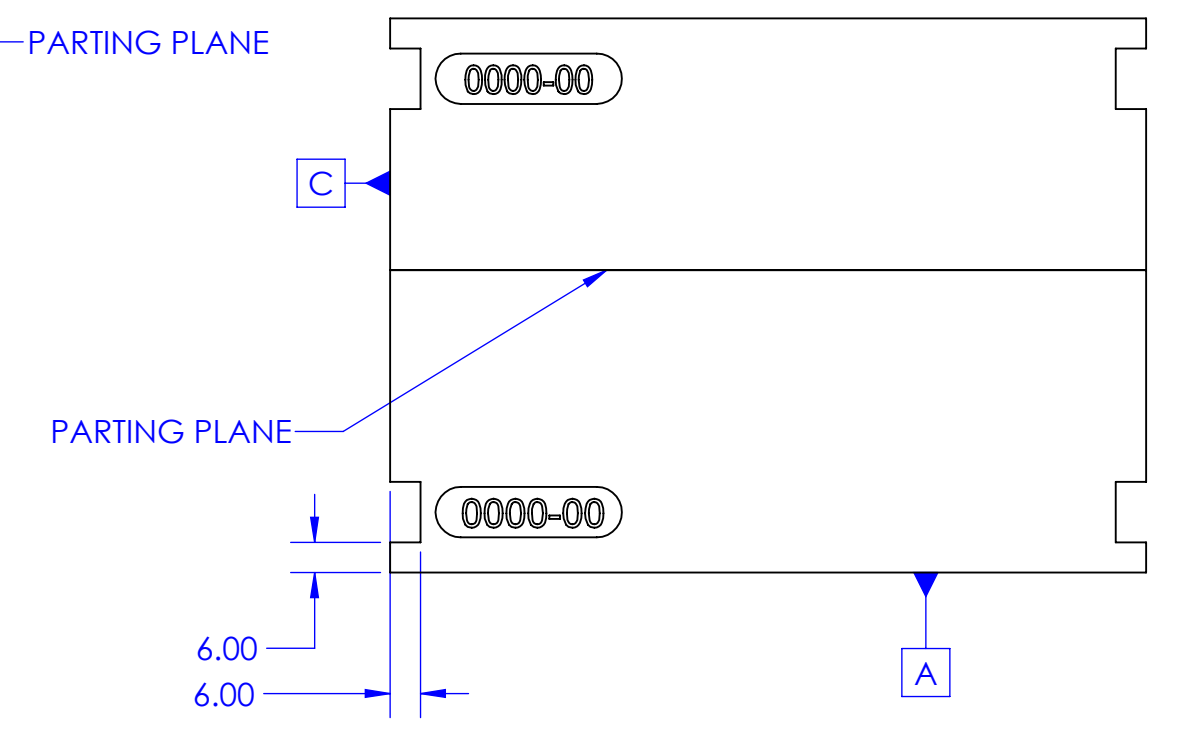
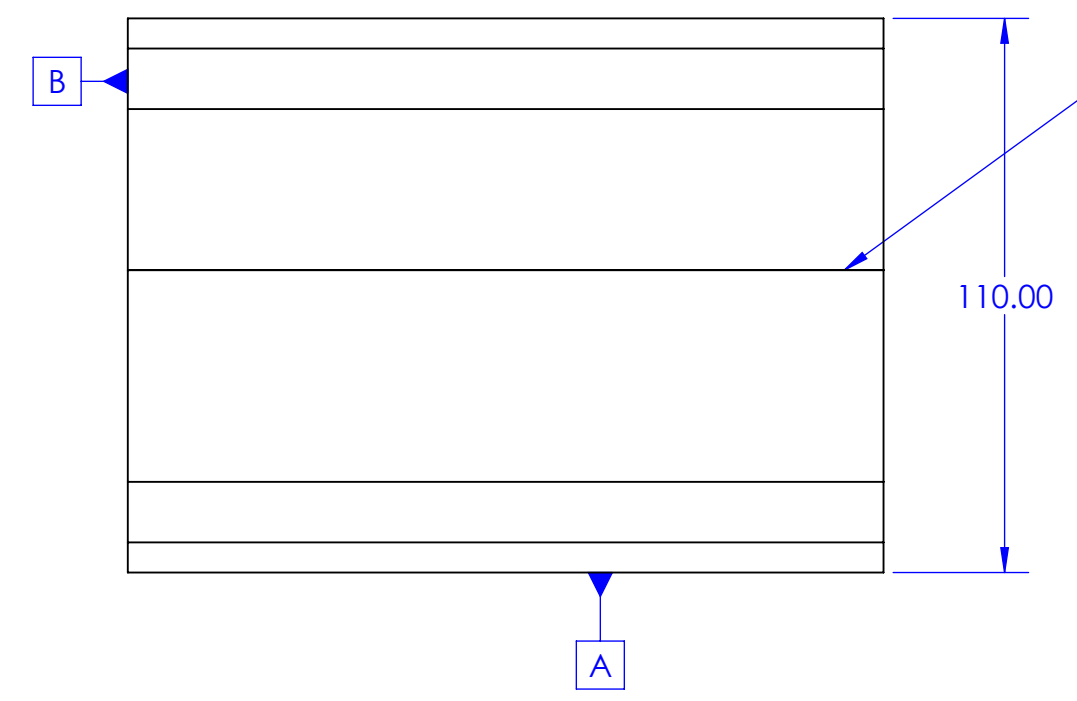
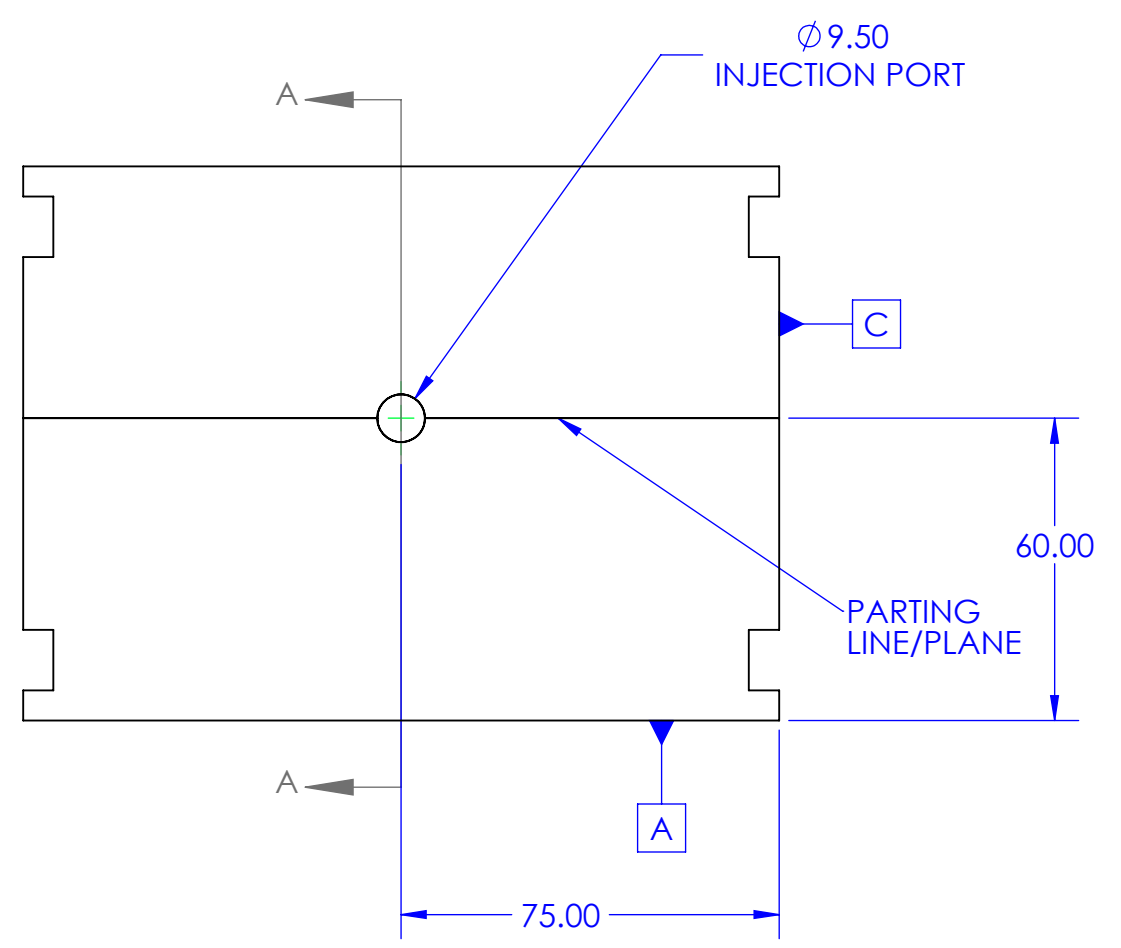
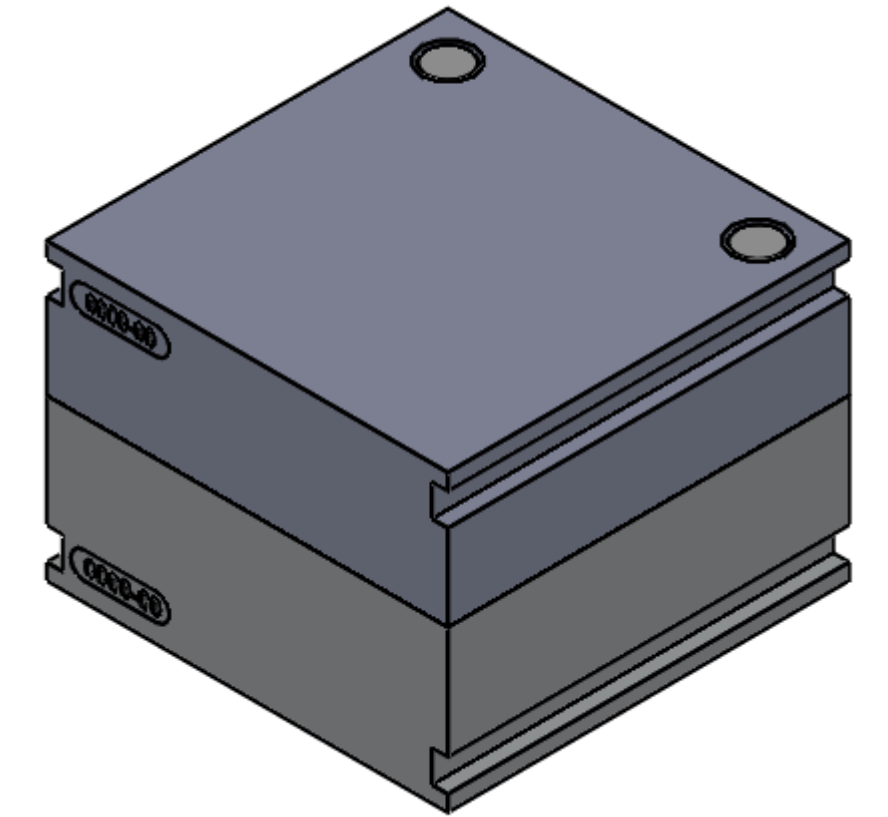
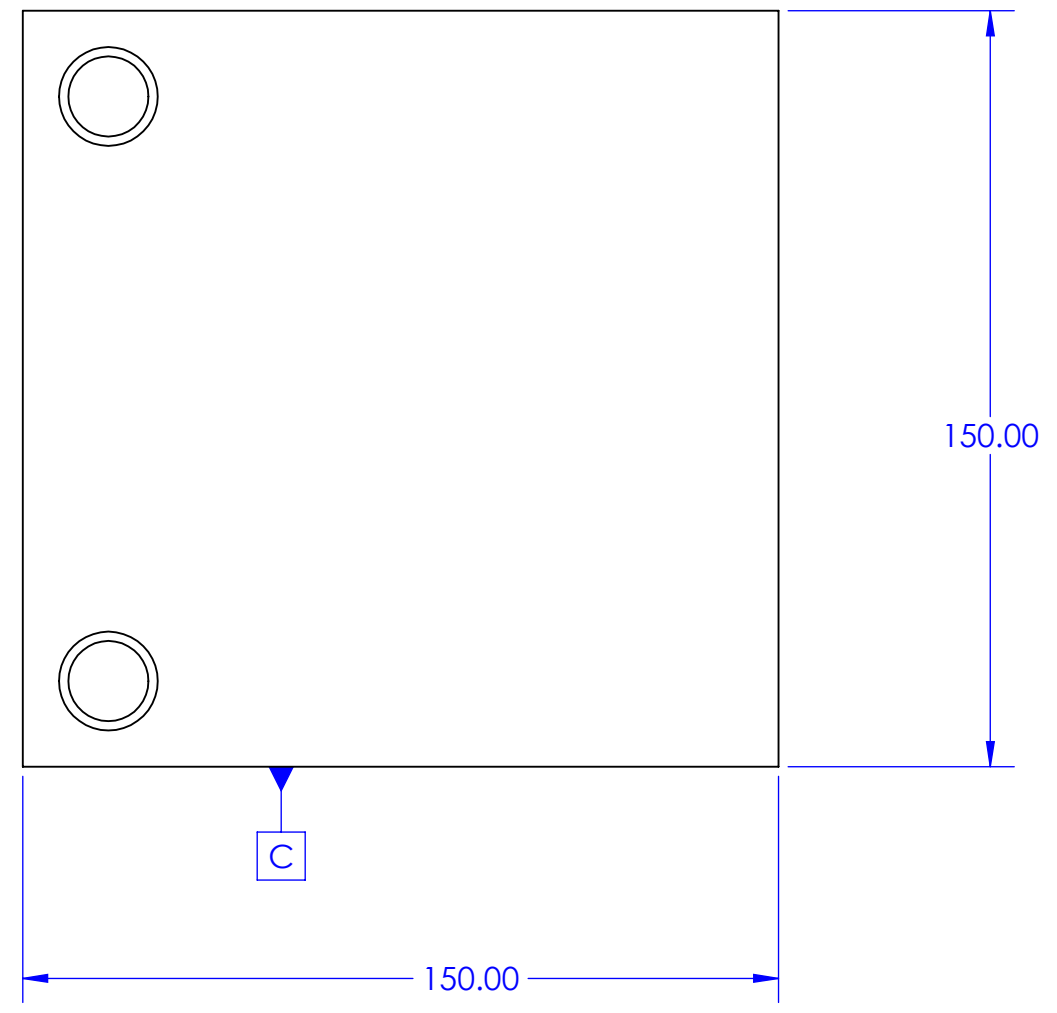

- NOTES:
- 1) BASE MATL: 7075-T6 ALUM
 - 2) 150x150x60 Mold Base, MM1050

Proprietary Notice: This drawing and the information contained herein is the property of Moldman Systems and may not be reproduced or used for other purposes than authorized by Moldman Systems.

UNLESS OTHERWISE SPECIFIED DIMENSIONS ARE IN MM. TOLERANCES ARE:		CAD GENERATED DRAWING : DO NOT MANUALLY UPDATE	MOLDMAN SYSTEMS 4649 Aircenter Dr. Ste 101, Reno, NV 89521 (775) 332-1600 fax: (775) 332-1601	
DECIMALS:	ANGLES:			
.X : +/- 0.7	X : +/- 0.5°	DO NOT SCALE DRAWING	TITLE MM1050, 150x150x60 Mold Blank	
.XX : +/- 0.25	X.X : +/- 0.1°		PART NUMBER	
.XXX : +/- 0.127		MATERIAL: SEE NOTES	APPROVALS	DATE
FINISH: SEE NOTES	CREATED DT 2015-08-20	CHECKED	SIZE C	DRAWING SCALE: n/a
				SHEET 1 OF 1
				REV. 01

1 2 3 4 5 6 7 8